

# 氣動式鑄鐵閘刀閥

## PNEUMATIC TYPE KNIFE GATE VALVE

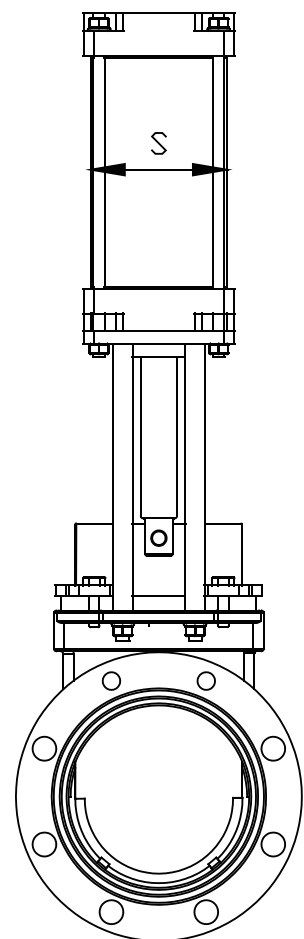
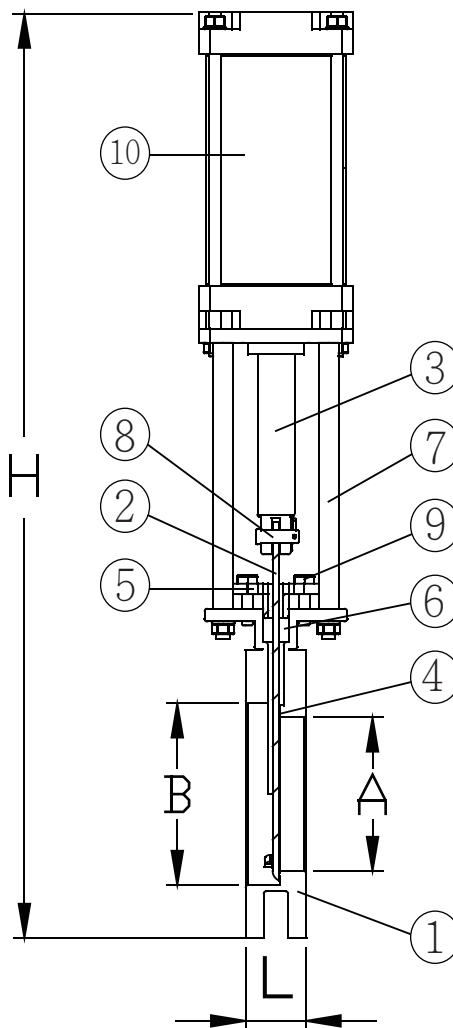

### DIMENSION : MM

SIZE	L	A	B	S	H
2"	55	42	64	63	520
2-1/2"	55	57	80	63	600
3"	55	72	95	80	650
4"	55	93	119	80	700
5"	60	116	141	125	980
6"	60	146	173	125	910
8"	70	190	215	150	1180
10"	75	235	260	180	1500
12"	80	280	310	200	1600
14"	80	330	376	250	1840
16"	90	375	420	250	2060
18"	90	430	480	250	2200
20"	120	475	520	300	2460
24"	120	570	630	300	2750

(FOR REFERENCE ONLY.)

### MATERIALS

NO.	SUBJECT	MATERIAL
1	BODY	FC FCD
2	PLATE	SUS304
3	STEM	SS41+HCr
4	SEAT	TEFLON
5	GLAND	CAST IRON
6	GLAND PACKING	ASB NON-ASB
7	YOKE	DUCTILE IRON
8	CONNECTOR	SUS304
9	BOLT	MILD STEEL
10	ACTUATOR	AIALLOY .FC

(FOR REFERENCE ONLY.)

### 連接規格 : (FLANGE)

- JIS 5K JIS 10K JIS7.5K
- ANSI 150LB
- DIN PN10 PN6

### MSS-SP81 TEST STANDARD

BODY TEST : 11kg / cm<sup>2</sup> (WATER)

SEAT TEST : 2.8kg / cm<sup>2</sup> (WATER)

LEAKAGE : 4 cc / per in.min.