

## 手動式鑄鐵閘刀閥

## MANUAL TYPE CAST IRON KNIFE GATE VALVE

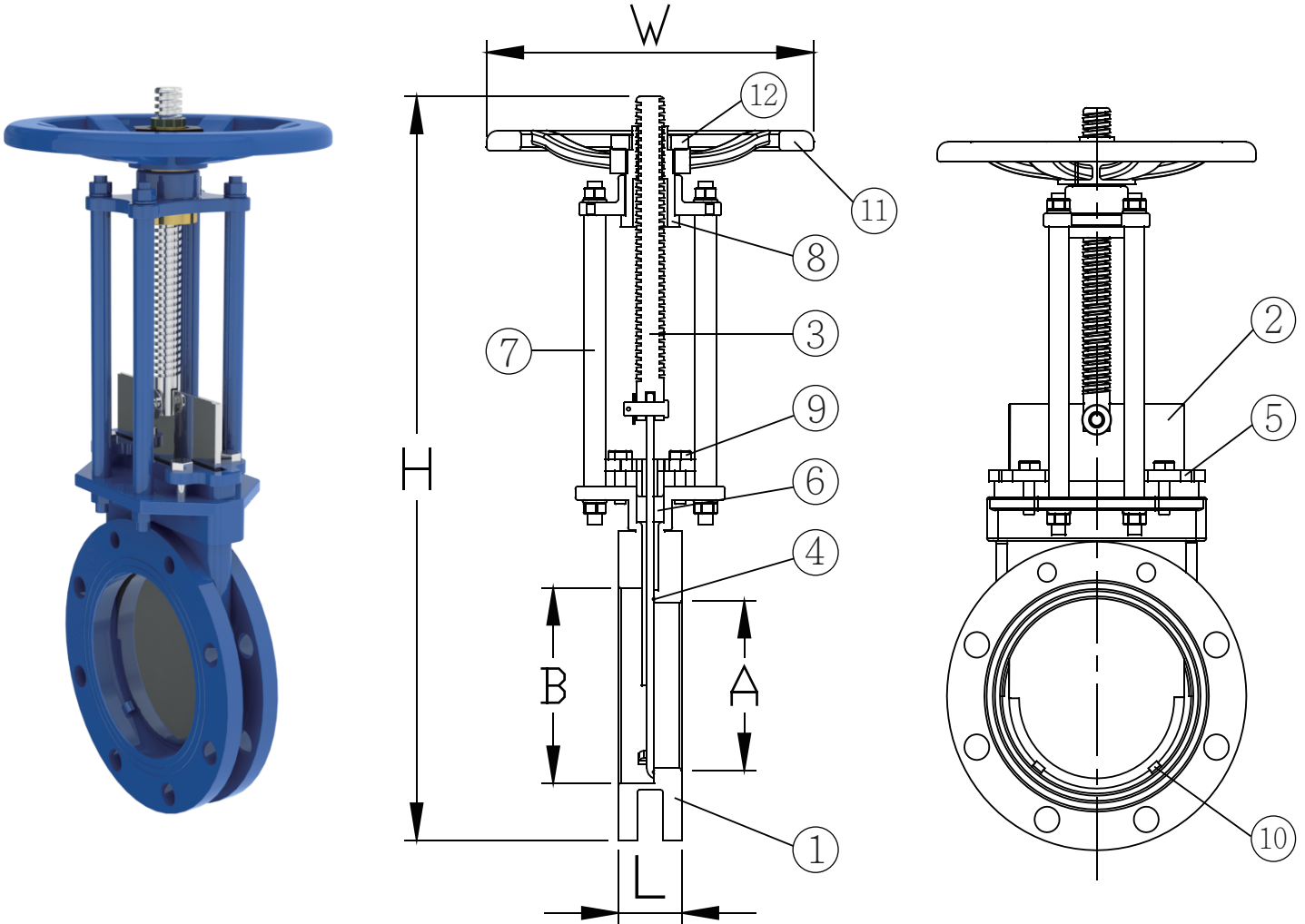

### DIMENSION : MM

SIZE	L	A	B	W	H
2"	55	42	64	190	420
2-1/2"	55	57	80	190	430
3"	55	72	95	190	430
4"	55	93	119	220	500
5"	60	116	141	290	700
6"	60	146	173	290	700
8"	70	190	215	350	880
10"	75	235	260	350	1100
12"	80	280	310	400	1150
14"	80	330	376	400	1200
16"	90	375	420	400	1410
18"	90	430	480	500	1570
20"	120	475	520	500	1700
24"	120	570	630	500	1970

(FOR REFERENCE ONLY.)

### MATERIALS

NO.	SUBJECT	MATERIAL
1	BODY	FC FCD
2	PLATE	SUS304
3	STEM	SUS410 SUS304
4	SEAT	TEFLON
5	GLAND	CAST IRON
6	GLAND PACKING	ASB NON-ASB
7	YOKE	DUCTILE IRON
8	YOKE SLEEVE	CAST BRONZE
9	BOLT NUT	MILD STEE
10	PAWLS	FC FCD
11	HAND WHEEL	CAST IRON
12	NUT	CAST IRON

(FOR REFERENCE ONLY.)

### 連接規格 : (FLANGE)

- JIS 5K JIS 10K JIS7.5K
- ANSI 150LB
- DIN PN10 PN6

### MSS-SP81 TEST STANDARD

BODY TEST : 11kg / cm<sup>2</sup> (WATER)

SEAT TEST : 2.8kg / cm<sup>2</sup> (WATER)

LEAKAGE : 4 cc / per in.min.